

**SERVICE PARTS LIST**

SPECIFY CATALOG NO. AND SERIAL NO. WHEN ORDERING PARTS		REVISED BULLETIN	DATE
<b>8" SAW MOTOR</b>			Sept. '92
CATALOG NO.	6466	STARTING SERIAL NO.	772-A
		WIRING INSTRUCTION	58-01-0750

EXAMPLE:  
Component Parts  
(Small #)  
Are Included When  
Ordering  
The Assembly  
(Large #).

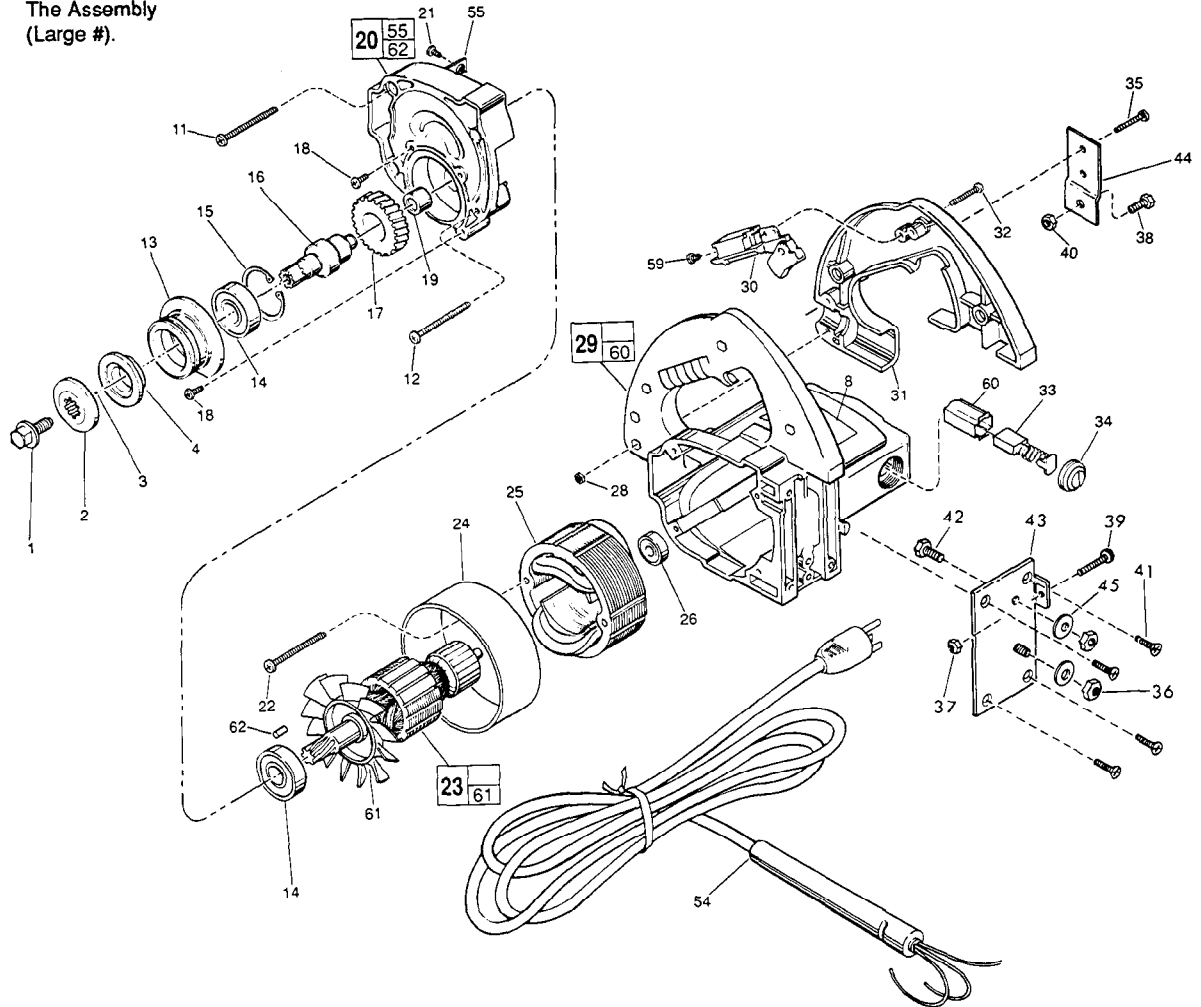

FIG.	PART NO.	DESCRIPTION OF PART	NO. REQ.	FIG.	PART NO.	DESCRIPTION OF PART	NO. REQ.
1	06-75-0477	Blade Screw	(1)	34	23-44-0160	Brush Retaining Screw	(2)
2	45-88-0286	Spindle Blade Retaining Washer	(1)	35	06-81-6560	8-32x1-1/2" Rd. Hd. Machine Screw	(2)
3		Blade	(1)	36	06-55-2420	3/8-16 Hex Nut	(2)
4	43-34-0540	Spindle Flange	(1)	37	06-55-1000	10-24 Hex Nut	(1)
8	12-20-0100	Nameplate Kit	(1)	38	06-75-0100	1/4-20x3/4" GR5 Hex Hd. Cap Screw	(1)
11	06-95-3270	8-16 x 1" Pan Hd. Screw	(3)	39	06-95-0341	10-24x3/4" Hex Washer Self-tapping Screw	(1)
12	06-82-7382	8-16 x 1-5/8" Pan Hd. Plastite T-20	(1)	40	06-55-1500	1/4-20 Hex Nut	(1)
13	43-78-0250	Lower Guard Hub	(1)	41	06-81-2590	10-16x5/8" Flat Hd. Fil. Dr. "B" Point	(4)
14	02-04-1748	Ball Bearing	(2)	42	06-75-0494	3/8-16x5/8" GR5 Hex Hd. Cap Screw	(2)
15	34-80-2960	Retaining Ring - Internal	(1)	43	44-66-6000	Front Mounting Plate	(1)
16	38-50-1075	Gear Spindle	(1)	44	44-66-6010	Rear Mounting Plate	(1)
17	32-75-2790	Spindle Gear	(1)	45	45-88-8460	5/16" Flat Washer	(2)
18	06-82-7252	8-32 x 3/8" Pan Hd. Slit Tap Tite T-20	(4)	54	22-64-0105	Cord Set	(1)
19	02-50-2423	Needle Bearing	(1)	55	42-36-1120	Ground Screw Bracket	(1)
20	14-30-0290	Gear Case Assembly	(1)	59	05-78-0305	Switch Screw	(4)
21	06-81-8820	Ground Screw	(1)	60	22-20-0350	Brush Insert	(2)
22	06-82-7453	8-16 x 2-1/4" Pan Hd. Plastite T-20	(2)	61	22-84-0655	Fan Assembly	(1)
23	16-70-0131	120 V. Armature	(1)	62	45-30-0110	Ball Bearing Retaining Slug	(1)
24	23-16-0691	Field Insulating Sleeve	(1)		49-96-6200	9/16" Wrench	(1)
25	18-70-0095	120 V. Field	(1)				
26	02-04-0850	Ball Bearing	(1)				
28	06-55-0835	8-32 Hex Nut	(5)				
29	31-50-0153	Motor Housing Assembly	(1)				
30	23-66-2090	Switch	(1)				
31	31-44-0481	L.H. Handle	(1)				
32	06-82-2362	8-32 x 1" Pan Hd. Slit T-20	(3)				
33	22-18-0147	Carbon Brush Assembly	(2)				

**FIG. LUBRICATION**  
20 1/2 Oz. Type "O" Grease, No. 49-08-4200.