



# SERVICE PARTS LIST

BULLETIN NO.  
54-40-0401

SPECIFY CATALOG NO. AND SERIAL NO. WHEN ORDERING PARTS		REVISED BULLETIN	DATE
<b>D.I. 7-1/4" CIRCULAR SAW</b>		54-40-0400	Oct. '95
CATALOG NO.	6369	WIRING INSTRUCTION <b>58-01-1260</b>	
STARTING SERIAL NO.	780B		

**EXAMPLE:**

Component Parts (Small #) Are Included  
When Ordering The Assembly (Large #).

FIG. PART NO.	DESCRIPTION OF PART	NO. REQ.
1	06-95-3241	(4)
2	28-53-0260	(1)
3	02-04-1701	(1)
4	34-80-2365	(1)
5	38-50-5600	(1)
6	32-75-3200	(1)
7	02-50-2423	(1)
8	06-82-7395	(4)
9	14-30-0481	(1)
10	34-40-4140	(1)
11	05-78-0305	(4)
12	06-82-7212	(2)
13	06-65-1534	(1)
14	45-08-0200	(1)
15	40-50-8040	(1)

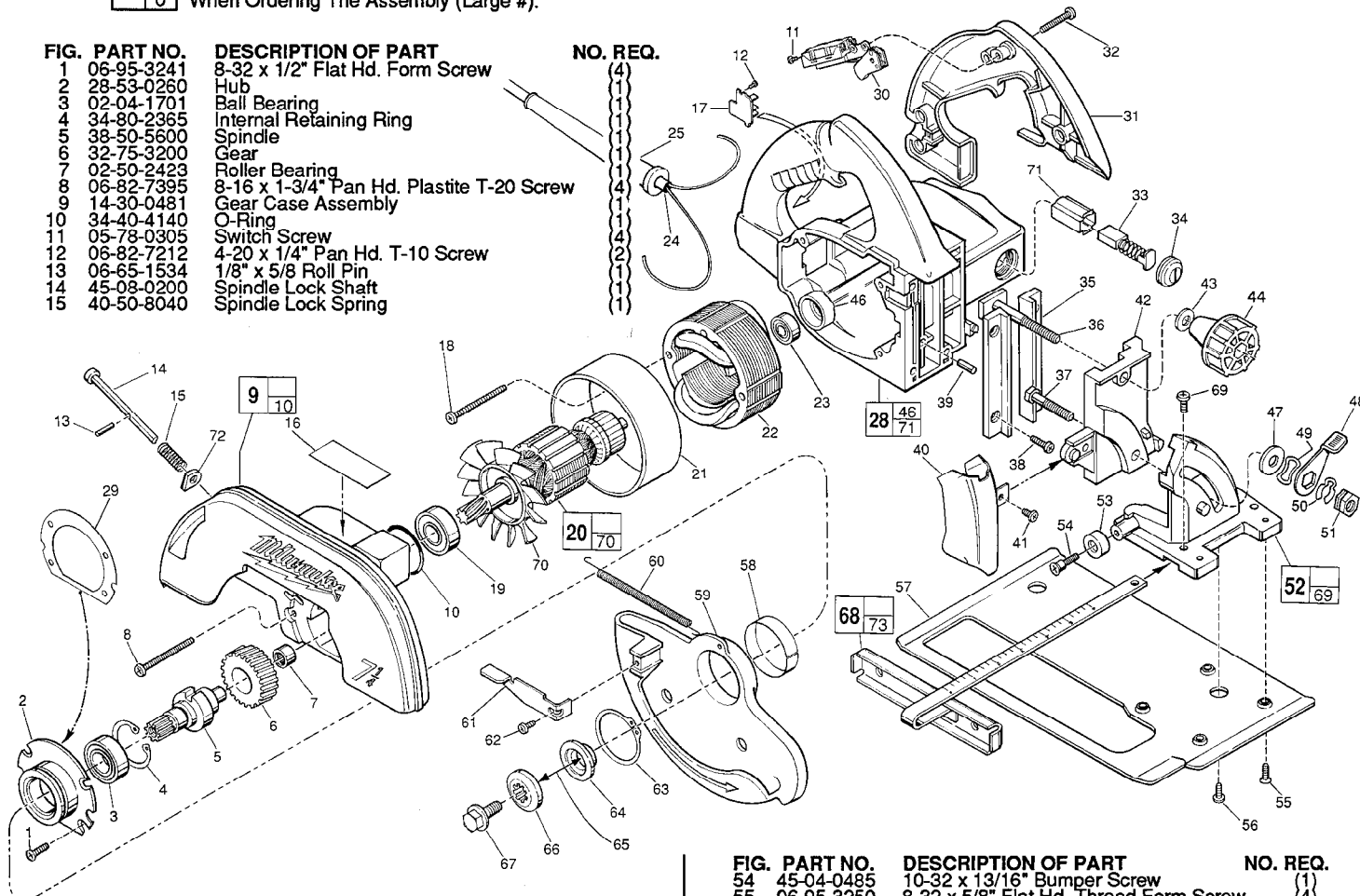

16	12-20-0050	Service Nameplate	(1)
17	14-20-0520	Brake Module	(1)
★ 18	06-82-7395	8-16 x 1-3/4" Pan Hd. Plastite T-20 Screw	(2)
19	02-04-1700	Ball Bearing	(1)
20	16-70-0500	120 V Armature	(1)
21	42-14-0310	Baffle	(1)
22	18-70-0500	120 V Field	(1)
23	02-04-0850	Ball Bearing	(1)
24	22-64-0785	Cord Set	(1)
25	44-76-0050	Cord Protector	(1)
★ 28	31-50-1041	Motor Housing Assembly	(1)
29	43-44-0800	Gasket	(1)
30	23-66-2100	Switch	(1)
31	31-44-1421	Handle Half-Left	(1)
★ 32	06-82-7326	8-16 x 1" Pan Hd. Slotted Plastite T-20	(4)
33	22-18-0735	Carbon Brush Assembly	(1)
34	23-44-0160	Brush Retaining Screw	(1)
35	28-72-0049	Vertical Adjusting Plate	(1)
36	45-58-0310	Vertical Adjusting Stud	(1)
37	45-58-0270	Angular Adjusting Stud	(1)
38	06-82-7270	8-16 x 5/8" Slotted Plastite T-20 Screw	(4)
39	06-65-1580	3/16" x 1/2" Roll Pin	(1)
40	43-54-0547	Front Blade Guard	(1)
★ 41	06-82-7253	8-32 x 3/8" Pan Hd. Taptite T-20 Screw	(1)
42	25-10-0799	Vertical Adjusting Bracket	(1)
43	45-88-0660	Adjusting Washer	(1)
★ 44	14-34-0190	Vertical Adjusting Knob Assembly	(1)
★ 46	42-96-0130	Bearing Cup	(1)
★ 47	45-88-8460	Angle Adjusting Washer	(1)
48	44-10-0200	Lever	(1)
49	45-88-0577	Wave Washer	(1)
50	34-60-2330	Klipring	(1)
51	44-40-0460	Adjustment Nut	(1)
52	28-10-0791	Angular Adjustment Bracket Assembly	(1)
53	42-38-0221	Rubber Bumper	(1)

FIG. PART NO.	DESCRIPTION OF PART	NO. REQ.	
54	45-04-0485	10-32 x 13/16" Bumper Screw	(1)
55	06-95-3250	8-32 x 5/8" Flat Hd. Thread Form Screw	(4)
★ 56	06-82-7253	8-32 x 3/8" Pan Hd. Taptite T-20 Screw	(1)
57	45-16-0570	Shoe	(1)
58	45-14-0230	Lower Guard Shim	(1)
59	28-41-0912	Lower Guard	(1)
60	40-50-4510	Lower Guard Spring	(1)
61	43-62-0910	Lower Guard Handle	(1)
★ 62	06-82-5317	8-32 x 1/2" Pan Hd. Taptite T-20 Screw	(1)
63	34-60-2195	External Retaining Ring	(1)
64	43-34-0560	Inner Flange	(1)
65		7-1/4" Blade	(1)
66	45-88-0286	Spindle Washer	(1)
67	06-75-0477	3/8"-24 x 11/16" Blade Screw	(1)
68	49-22-4150	Rip Fence (Optional)	(1)
69	06-95-0335	1/4"-20 x 1/2" Fil. Hd. Screw	(2)
70	22-84-0655	Fan Assembly	(1)
71	22-20-0820	Brush Insert	(2)
	49-96-6200	9/16" Utility Wrench	(1)
72	45-88-8250	Felt Seal	(1)
73	06-87-2450	1/4-20 x 1/2" Thumb Screw	(2)

**FIG. LUBRICATION**

- 9 3/4 Oz. Type "O" Grease, No. 49-08-4200.
- 35,42,52 Apply a thin coat of teflon dry spray lubricant to all sliding surfaces.
- 2,58,59 Apply a light coat of Artic Grease, No. 49-08-4100 to lower guard bore, faces of hub O.D. and all mating surfaces.

**FIG. NOTES**

- 14 Flat in spindle lock shaft must face gear.
- 41,62 Apply Blue Loctite, Type CV-242.
- 60 Hooks of spring must be completely inserted in slots. Long hook in upper guard.

MILWAUKEE ELECTRIC TOOL CORPORATION  
13135 W. LISBON RD., BROOKFIELD, WI 53005