



SERVICE PARTS LIST

BUL. 54-40-1520

8-1/4" MITER SAW

REVISED BUL 6178-1 DATE Feb. '68

Catalog No. 6380

Starting Serial No. **178-1001**

WIRING INSTR.

Both Model and Serial No. must be furnished to obtain correct parts.

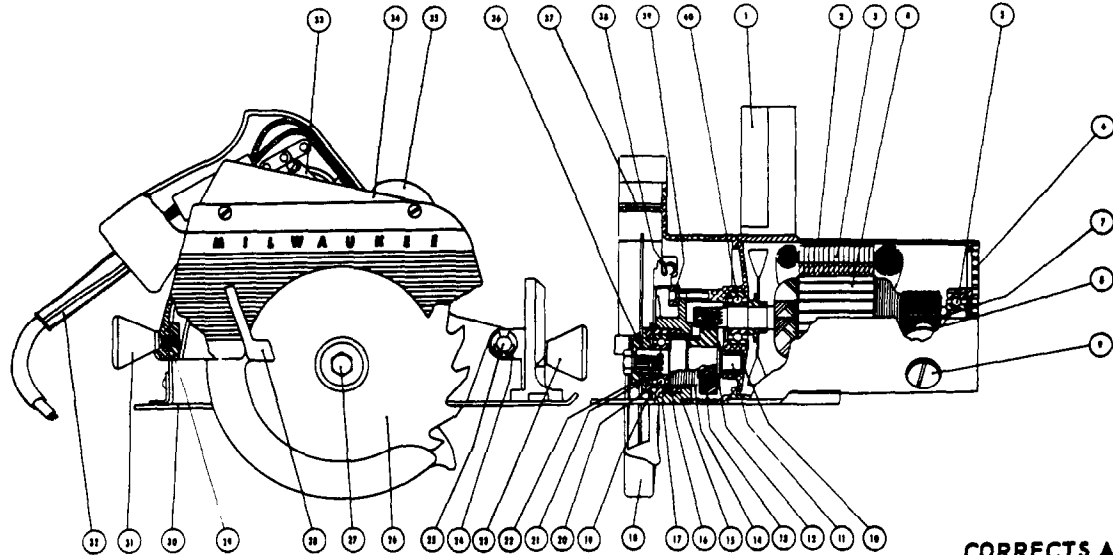

CORRECTS AND SUPERCEDES SERVICE BULLETIN 6178-1 DATED 3/1/60

ILLUSTRATED PARTS		
FIG.	PART NO.	DESCRIPTION OF PART
1	28-20-3121	Saw Handle Cover
2	28-50-4721	Saw Body
3	18-82-1085	Field Assembly
4	16-82-1310	Armature Assembly
5	02-04-1070	Ball Bearing (Comm.)
6	28-39-0201	Air Intake Grill
7	22-18-0095	Carbon Brush Assembly
8	22-22-0065	Brush Holder Assembly
9	23-44-0050	Brush Retaining Screw Assembly
10	02-50-2440	Needle Bearing
11	38-50-3351	Spindle
12	34-60-1600	Spindle Gear Retaining Ring
13	32-75-1841	Spindle Gear
14	40-50-2800	Spindle Drive Spring
15	28-72-6361	Spindle Bearing Plate
16	34-80-2500	Spindle Ball Brg. Ret. Ring
17	45-88-0280	Spindle Drive Spring Washer
18	28-41-0302	Saw Guard Assembly
19	34-60-2200	Saw Guard Ret. Ring
20	02-04-1640	Spindle Ball Bearing
21	34-60-1500	Spindle Retaining Ring
22	43-34-0080	Spindle Flange
23	43-98-0070	Miter Plate Adjusting Knob
24	34-60-0800	Pivot Pin Ret. Ring
25	44-60-0180	Pivot Pin
26	48-40-1821	Saw Blade, Combination
26A	48-40-2822	Saw Blade, Cross Cut
26B	48-40-8823	Saw Blade, Rip
26C	48-40-5824	Flooring Blade (Nail Cutting)
27	06-75-0475	3/8-24x3/4 Hex.Hd.Blade Ret. Cap Screw
28	28-44-5001	Saw Guard Handle
29	44-40-0150	Depth Adjusting Nut
30	45-16-0140	Saw Shoe Assembly
31	43-98-0080	Depth Adjusting Knob
32	22-64-0080	Cord Set
33	23-66-0300	Switch
34	28-20-1041	Diaphragm Cover
35	43-98-0060	Hand Knob
36	45-88-0290	Spindle Washer
37	28-28-0901	Diaphragm
38	40-50-2300	Saw Guard Spring
39	42-38-0070	Saw Guard Bumper
40	02-04-1460	Ball Bearing (Pinion End)

MISCELLANEOUS PARTS NOT SHOWN			
PART NO.	DESCRIPTION OF PART	PART NO.	DESCRIPTION OF PART
49-96-6300	9/16 Wrench	06-81-3600	8-32x3/8 Oval Hd. Saw Guard Handle Screw
49-96-6400	1-3/8 Wrench	06-81-3600	8-32x3/8 Oval Hd. Diaphragm Cover Screws
12-98-1200	Name Plate	06-81-3700	8-32x7/8 Oval Hd. Handle Cover Screws
06-81-8200	4-36x3/16 Rd.Hd. Sems Name Plate Scs.	06-81-7300	10-24x1-3/4 Fil. Hd. Spindle Brg. Plate Sc. (Sem)
06-81-3450	6-32x5/16 Oval Hd. Air Vent Grill Screws	28-39-0501	Air Vent Grill
06-81-3450	6-32x5/16 Oval Hd. Air Intake Grill Screws	43-30-0051	Rip Fence
06-81-9000	8-32x3-1/8 Rd.Hd. Field Screws (Sems)	06-87-5000	1/4-20x7/8 Rip Fence Thumb Screw
06-81-7000	10-24x5/8 Fil.Hd. Diaphragm Screws (Sems)	45-88-5240	1/2x17/64x1/32 Miter Plate Adjusting Knob
06-81-2700	10-24x1-3/4 Flat Hd. Spindle Brg. Plate Scs.	06-81-6050	8-32x5/16 Fil.Hd.Sem Guard Bumper Screw
06-81-3950	10-24x3/8 Oval Hd. Spindle Brg. Plate Scs.	45-88-0240	Depth Adjusting Knob Washer
06-81-3750	8-32x1 Oval Hd. Handle Cover Screws	42-14-0070	Baffle
06-83-2670	1/4-20x1/2 Hd'less Brush Holder Set Screws	45-36-0190	Baffle Spacer
06-81-5400	8-32x5/16 Binder Hd. Switch Mtg. Scs. (Sems)	45-12-0080	Eye Shield
42-32-0070	Carriage Mitering Plate Bolt	06-81-8200	4-36x3/16 Rd.Hd. Sem Eye Shield Mtg. Screws (2)
06-81-8625	6-32x1/4 Rd.Hd.Ground Wire Sc.(Brass)(Sem)	48-03-0010	Attachment Plug Adapter