

WIRING INSTRUCTIONS

TITLE

CIRCULAR SAW

BULLETIN
58-01-0752

MILWAUKEE ELECTRIC TOOL CORP.

13135 WEST LISBON RD. BROOKFIELD, WIS

DATE

MAR '86

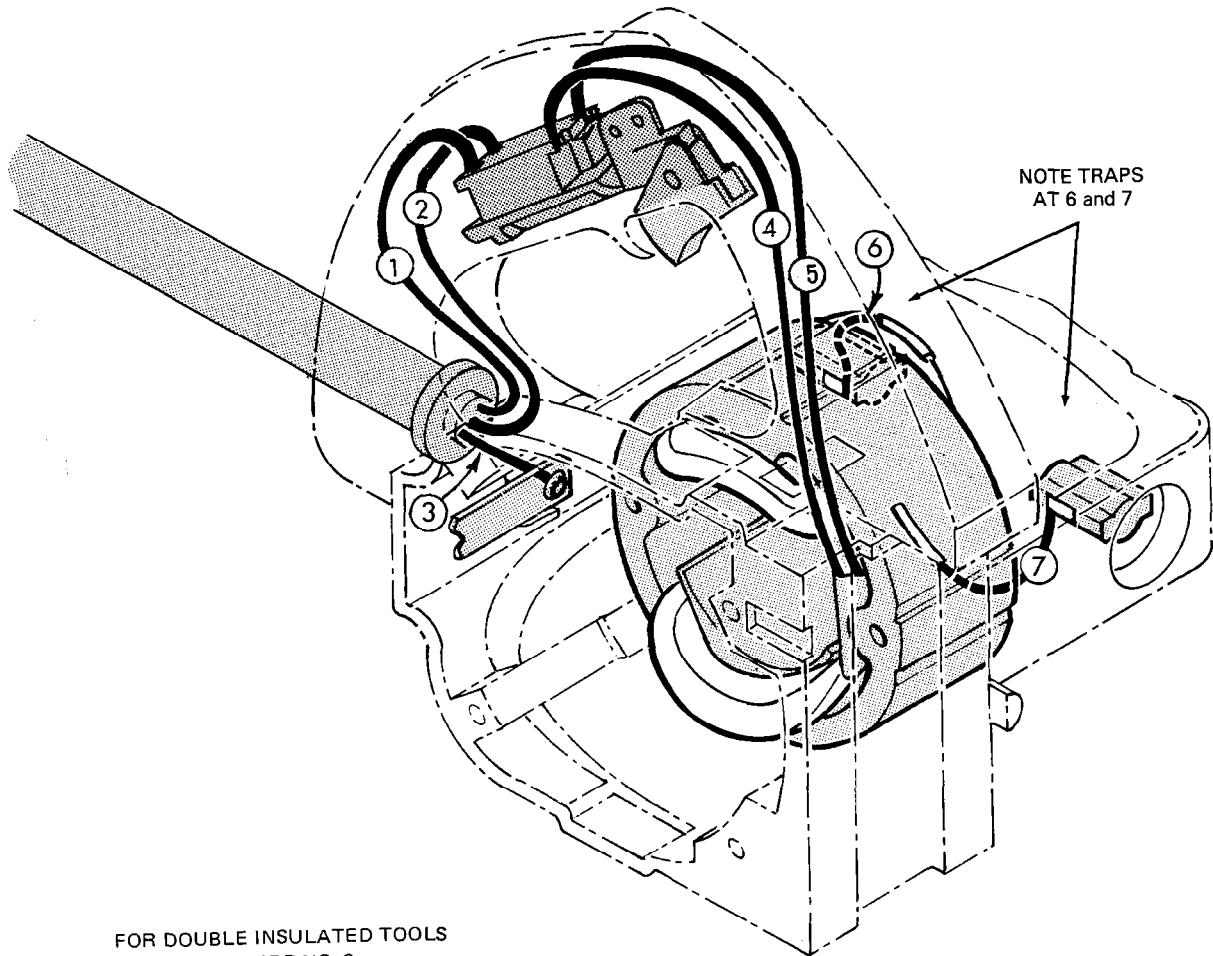

NOTE TRAPS
AT 6 and 7

FOR DOUBLE INSULATED TOOLS
DISREGARD WIRE NO. 3

AS AN AID IN REASSEMBLY, TAKE NOTE OF WIRE ROUTING AND
POSITION IN WIRE GUIDES AND TRAPS WHILE DISMANTLING TOOL.

WIRING SPECIFICATIONS

Wire No.	Wire Color	Origin or Gauge	Length	Terminals, Connectors and 1 or 2 End Wire Preparation
1	WHITE	CORD	4-1/2"	STRIP 3/8" AND TIN
2	BLACK	CORD	4-1/2"	STRIP 3/8" AND TIN
3	GREEN	CORD	2"	STRIP 3/16" FOR T1
4	YELLOW	FIELD	8-7/8"	STRIP 3/8" AND TIN
5	BLACK	FIELD	8-7/8"	STRIP 3/8" AND TIN
6	YELLOW	FIELD	3-1/4"	STRIP 1/4" FOR T2
7	BLACK	FIELD	3-1/4"	STRIP 1/4" FOR T2

NOTE:

All leads must be held to $\pm 1/8"$.
All field leads to be measured from
and perpendicular to laminations.
All lead lengths are before stripping.

TERMINAL DESCRIPTION

Code	Part No.	Qty.
T1	23-74-0896	1
T2	22-44-0090	2

CONNECTOR DESCRIPTION

Code	Part No.	Qty.