

# WIRING INSTRUCTIONS

**TITLE**

**CIRCULAR SAW**

**BULLETIN  
58-01-0753**

**MILWAUKEE ELECTRIC TOOL CORP. 13135 WEST LISBON RD. BROOKFIELD, WIS.**

**DATE  
Oct. '92**

NOTE: Wires to be inserted in switch so that insulation is subflush to opening.

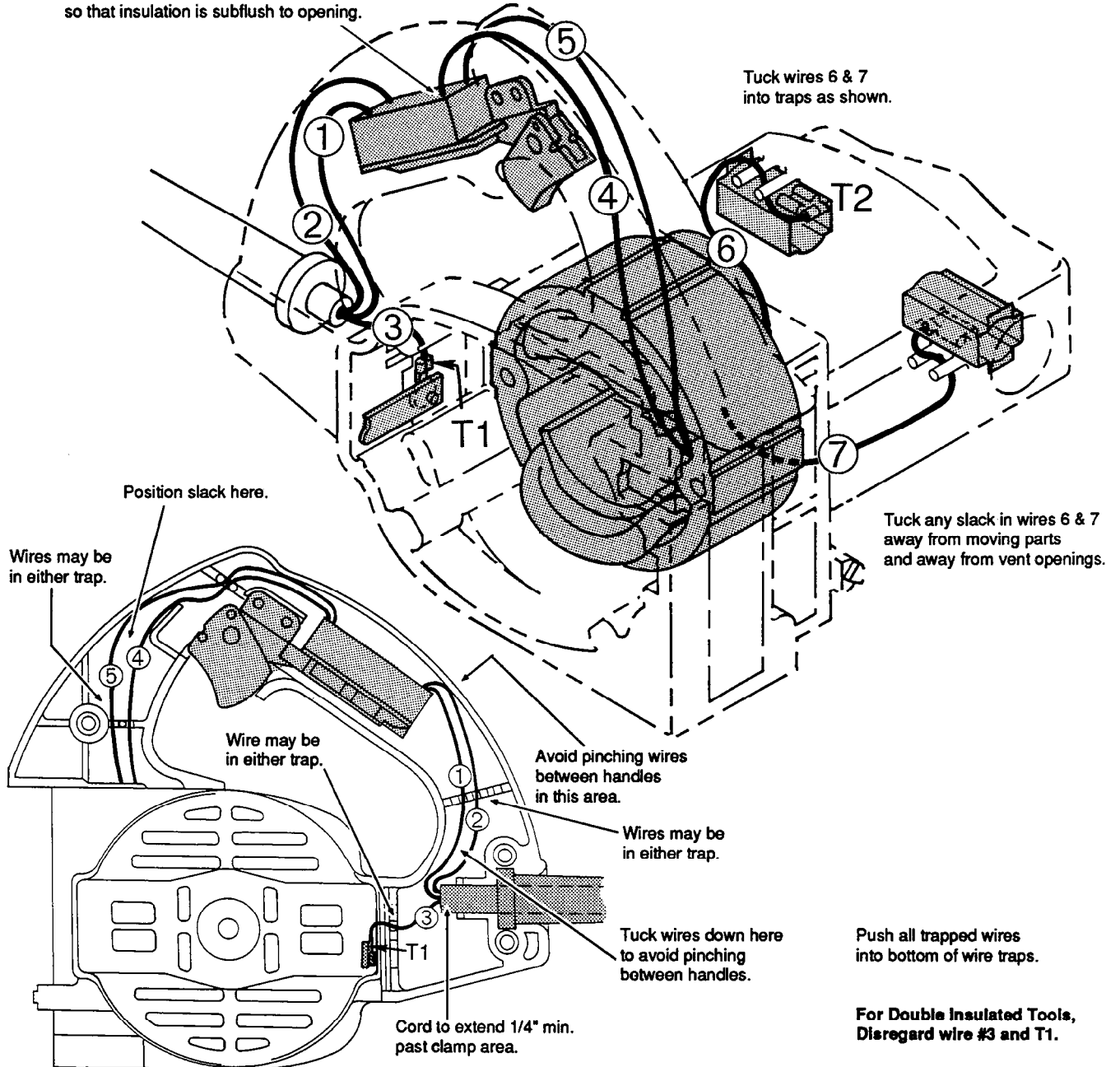

Push all trapped wires into bottom of wire traps.

**For Double Insulated Tools,  
Disregard wire #3 and T1.**

## WIRING SPECIFICATIONS

Wire No.	Wire Color	Origin or Part No.	Gauge	Length	Terminals, Connectors and End Wire Preparation
1	White	Cord	16	5"	Strip 3/8" and tin.
2	Black	Cord	16	5"	Strip 3/8" and tin.
3	Green	Cord	16	2-1/4"	Strip 3/16" for T1.
4	Yellow	Field	16	8-7/8"	Strip 3/8" and tin.
5	Black	Field	16	8-7/8"	Strip 3/8" and tin.
6	Yellow	Field	16	3-1/2"	Strip 3/16" for T2.
7	Black	Field	16	3-1/2"	Strip 3/16" for T2.

NOTE:  
All leads must be held to  $\pm 1/8"$ .  
All lead lengths are before stripping.

TERMINAL DESCRIPTION		
Code	Part No.	Qty.
T1	23-74-0896	1
T2	23-74-0300	2